



Product Data

A/SCTA Series Split-Core 4-20 mA Output Current Sensors

Current



Product Description

The A/SCTA Series current sensors monitor the current flowing to electrical equipment or buildings. The magnitude of this current is then converted into a linear and proportional 4 to 20 mA output signal, which can be monitored by your Building Management, DDC, or PLC controller. The A/SCTA Series current sensors are available in either an Average or True RMS output version. All of these sensors have jumper selectable input ranges except for the 0 to 5 Amp input range.

The A/SCTA series current sensors are fast acting and extremely accurate from 1 to 100% of the Full Scale Output. All of the A/SCTA series current sensors are factory calibrated using an NIST Traceable standard and shipped with the jumper placed in the largest jumper selectable range.

In applications where the maximum current is larger than 200 Amps, ACI recommends the use of a traditional ratio:5 (5A) current transformer and the A/SCTA-5 for best results. The A/SCTA must be externally powered using a +12 to 30 VDC power supply.

Product Specifications

Sensor Supply Voltage (Vs)	+12 to 30 VDC
Amperage Rating	0-200 Amps (See Ordering Information)
Supply Current	36 mA max.
Output	4-20mA, 2-wire Loop Powered
Accuracy (from 1-100% of FSO)	A/SCTA: +/- 0.5% A/SCTA-VFD: +/- 0.5%
Maximum Load Resistance	A/SCTA: 700 Ohms @ 24VDC (Vs-9)/0.02-40.2 A/SCTA-VFD: 650 Ohms @ 24VDC (Vs-10)/0.02-40.2
Response Time	A/SCTA: < 75mS A/SCTA-VFD: <200mS
Operating Frequency Range	30 to 1 kHz
Isolation Voltage	2,200 VAC
Max. Sensing Current Voltage	600 VAC
Aperture (Hole) Size	0.75", Accepts up to 350 MCM Cables
Operating Tem Range	A/CTA -15 to 40°C (5 to 104°F) A/CTA-VFD 0 to 40°C (32 to 104°F)
Operating Humidity Range	0 to 95% RH, non-condensing

Attributes:

- Split-Core design for retrofit applications
- Integral 35mm Din-rail mounting flange
- Limited 5 year warranty
- True RMS versions Available (VFD models)
- High Accuracy
- UL94-5VB (enclosure rating)

Applications:

- Load trending equipment (current monitoring)
- Load Trending building current consumption
- Rated for industrial use

DISPLAYS

TEMPERATURE

RELATIVE HUMIDITY

PRESSURE

CURRENT

AIR QUALITY

ACCESSORIES

Dimensions

Split-Core

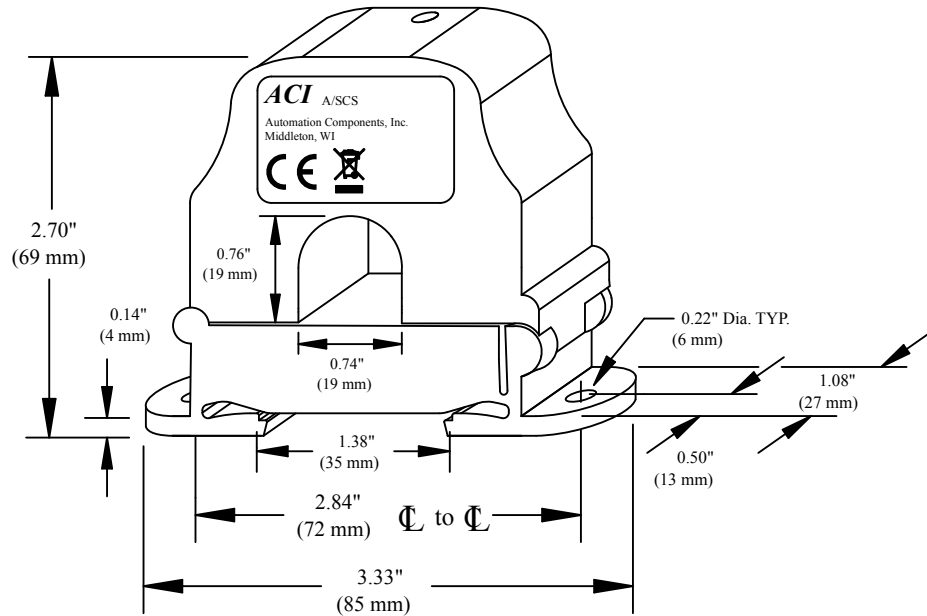

Ordering Information

ACI Model #	Description	Jumper Selectable Range	CE Compliant
A/SCTA-5	Loop Powered, Split-Core, 4-20 mA Average Output	0-5 Amps (<i>Not Selectable</i>)	Yes
A/SCTA-50	Loop Powered, Split-Core, 4-20 mA Average Output	0-10, 0-20, 0-50 Amps	Yes
A/SCTA-200	Loop Powered, Split-Core, 4-20 mA Average Output	0-100, 0-150, 0-200 Amps	Yes
A/SCTA-5-VFD	Loop Powered, Split-Core, True RMS, 4-20 mA Output **	0-5 Amps (<i>Not Selectable</i>)	No
A/SCTA-50-VFD	Loop Powered, Split-Core, True RMS, 4-20 mA Output **	0-10, 0-20, 0-50 Amps	No
A/SCTA-200-VFD	Loop Powered, Split-Core, True RMS, 4-20 mA Output **	0-100, 0-150, 0-200 Amps	No

**Note: All -VFD options should be used with VFD's (Variable Frequency Drives)



Warning: *Not intended to be used in Life & Safety Applications or for use in any hazardous locations.*

DISPLAYS
TEMPERATURE
RELATIVE HUMIDITY
PRESSURE
CURRENT
AIR QUALITY
ACCESSORIES